

# SpeedROC 1F

Surface drill rig for marble, granite, sandstone and limestone in the dimension stone industry.

Hole diameter: 28–45 mm (1.1"–1.8")



# Big capacity in a small unit

SpeedROC 1F, a small, hydraulic mobile drilling unit, is our high quality, high capacity drilling unit for the dimension stone industry.

Tailor-made for marble, granite and sandstone quarries, SpeedROC 1F provides you with straight holes. It gives you a low total cost of ownership (TCO) with its high drilling productivity,

drilling speed up to 2 m/min (6.5 ft/min), low fuel consumption of 6 l/h (1.6 US gal/h) and an efficient operation, that you can complement with the horizontal drilling option.



## ⊕ Main benefits

**Tailor-made** for the dimension stone industry

**Parallel and straight holes** means high quality output

**High drilling capacity** means better productivity

# Boost your productivity

Thanks to its productivity boosting features like anti-jamming system, guide rails and 3-way steering the SpeedROC 1F will increase your quality output and lower your total cost of ownership.



## + Precise dimensions cut costs

In the drilling process, SpeedROC 1F's precise output dimensions help ensure a high quality product, while exact measurements also contribute to low loading and transportation costs.



## + Rails keep you in line

Combining the unit's stability with an anti-jamming system and guide rails, ensures holes are parallel to each other and aligned in a straight line. This makes for high drilling quality and capacity.



## + Better working conditions

The rig is equipped with a Radio Remote Control which allows a safe operation. Furthermore, the effective dust collector system grants an high suction capacity with a reduction of the noise level emission. The hydrostatic transmission and 3-way steering system is a unique feature of the machine which improves the tramping capacity and aids climbing gradients in tough working conditions.



## A comprehensive service offering

Even the best equipment needs to be serviced regularly to make sure it sustains peak performance. An Epiroc service solution offers peace of mind, maximizing availability and performance throughout the lifetime of your equipment. We focus on safety, productivity and reliability.

By combining genuine parts and an Epiroc service from our certified technicians, we safeguard your productivity – wherever you are.

## Technical specifications

### Main Components

- One hydraulic rock drill, COP DS5.
- Aluminium feed with rail bar.
- Two independent hydraulic stabilizer legs.
- Rail bar.
- Folding boom.

- Self propelled four-wheel drive unit.
- CANBUS control system.
- Cummins engine.
- Screw compressor.
- Dust collector system.

### DSI applications

Marble-, granite-, sandstone-, and limestone quarries

### DSI operations

Primary cut drilling  
Bench dressing  
Block dressing

### Hydraulic system

Variable displacement main pump with load-sensing control system  
Gears secondary pump for starting the dust collector system and radiator oil cooling device  
Automatic device of oil pre-heating system  
Oil cooling system  
Anti-jamming device  
Proportional control hydraulic valves  
10 micron absolute oil filtration

### Hydraulic rock drill

COP DS5	Metric	US
Hole diameter	28 – 45 mm	1.1"-1.8"
Weight	45 kg	99 lb
Max impact power	5 kW	6.7 hp
Hydraulic pressure	155 bar	2 248 psi
Impact rate	68 Hz	
Shank type	HEX 22x108	

### Control system

Radio Remote Control  
3 electronic power stations  
Drilling low start device concerning both the thrust- and the percussion pressure

### Engine

Cummins OSB 3.3 Tier 4i	Direct injection	4 cylinders	110 hp/82 kW
Cummins B 3.3 Tier 3	Direct injection	4 cylinders	85 hp/63 kW

### Compressor

FAD, at normal working pressure	22 l/s	46 cfm
Maximum pressure	6 bar	87 psi
Mod E3		

### Dust collector

Filtering surface	6 m <sup>2</sup>	65 sq.ft
Suction capacity	97 l/s	206 cfm
Number of filters: 2		
Automatic cleaning system of the filters		

### Drilling unit

Starter rod	2 400 mm	94.5'
Rail bar with travel length	3 700 mm	145.7'
Rail bar with travel length	3 050 mm	120.1'
2 independent hydraulic stabilizer legs		
Rail bar front rotation +/-20°		
Rail bar lateral rotation +/-20°		
Rail bar horizontal rotation +/-90°		
Aluminium feed with hardened steel inserts for slide advancing with hydraulic approaching device to the ground		
Chain feed slide with hydraulic engine		
Sliding block in self lubricating composite		
Fast system steel retainer		

### Folding boom

Length boom	4 800 mm	189'
Swing boom rotation +/-35°		

### Electrical system

Voltage: 24 V  
Batteries: 2 x 12V 100 Ah  
Alternator: 55 A

### Carrier

Axles: equipped with three steering systems  
Front axle rigid to the frame  
Balancing rear axle  
4 drive steering wheels  
4 hydraulic stabilizer legs  
Hydrostatic transmission at closet circuit with pump and variable-powered pistons hydraulic motor  
Differential automatic blocksystem

### Tramming

Tramming speed	5 km/h	3.1 mph
----------------	--------	---------

### Environment

Temperature limits	-20°C – +45°C	-4°F – +113°F
Maximum altitude	2 300 m	7 546 ft

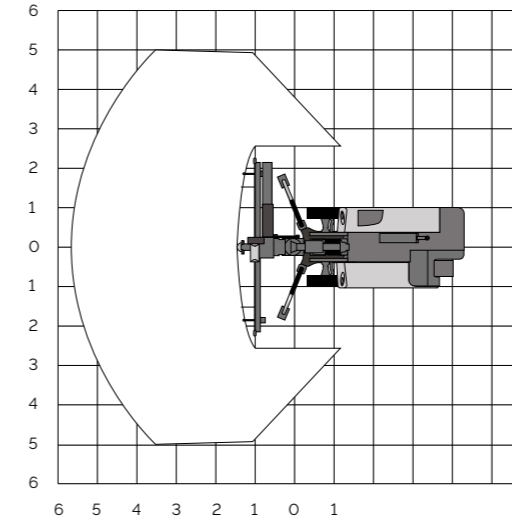
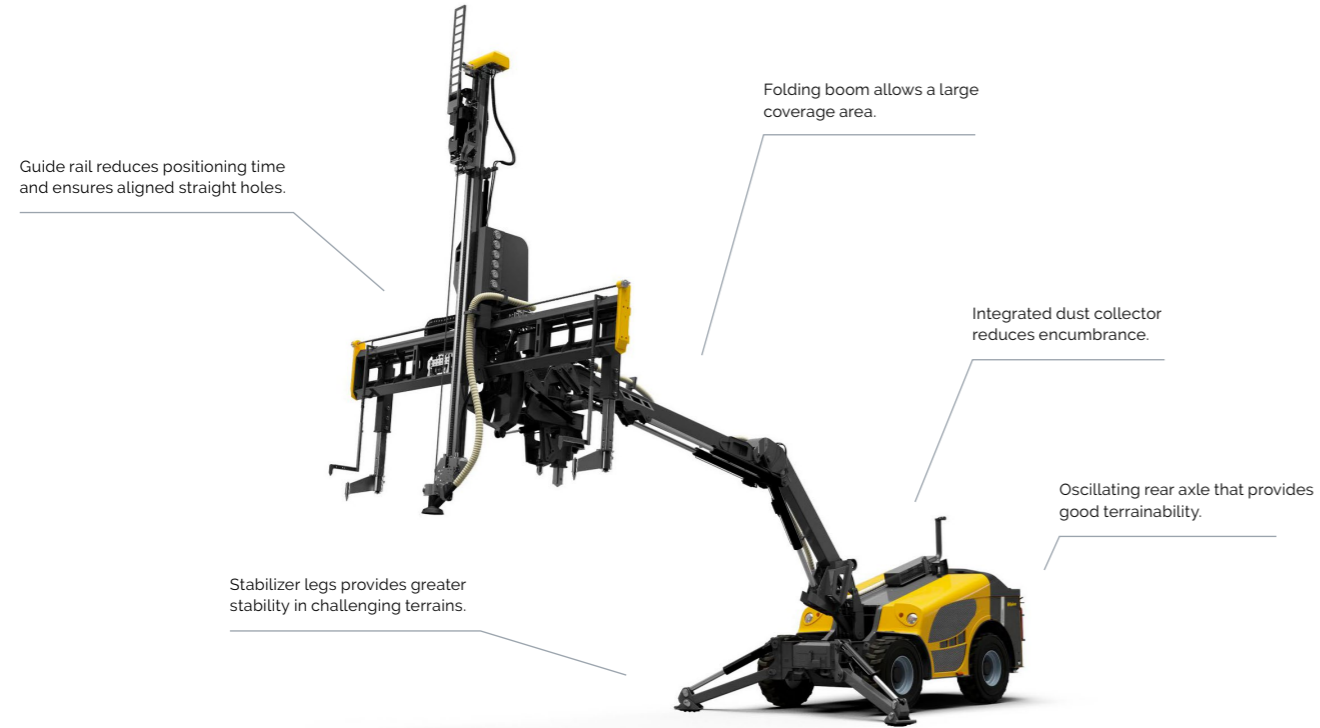

Horizontal reach - vertical drilling (m)

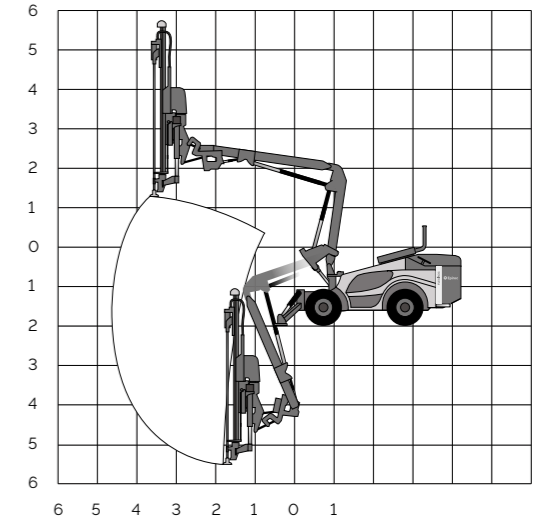

Vertical reach - vertical drilling (m)

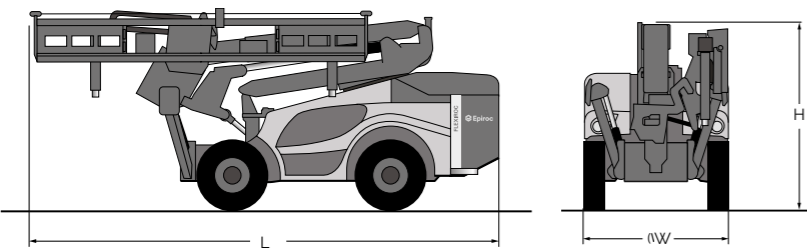

**Transport dimensions and weight**

	Metric	US
Length (L)	5 900 mm	232.3"
Width (W)	2 200 mm	86.6"
Height (H)	2 380 mm	93.7"
Weight	5 900 kg	13 000 lb

Standard unit excluding all options and drill rod

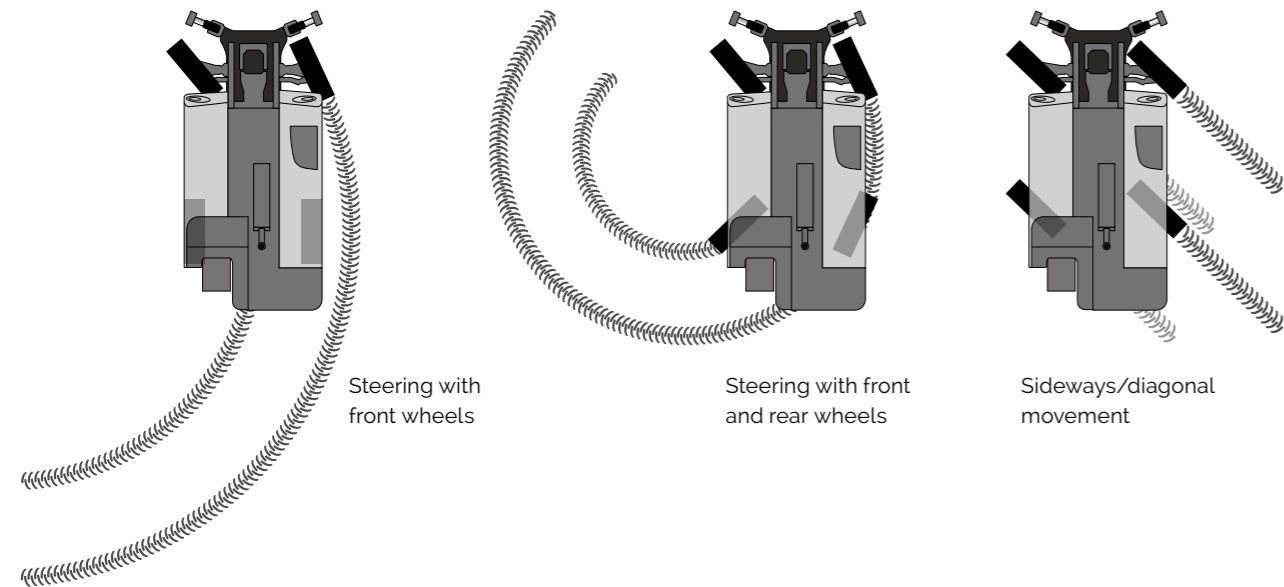
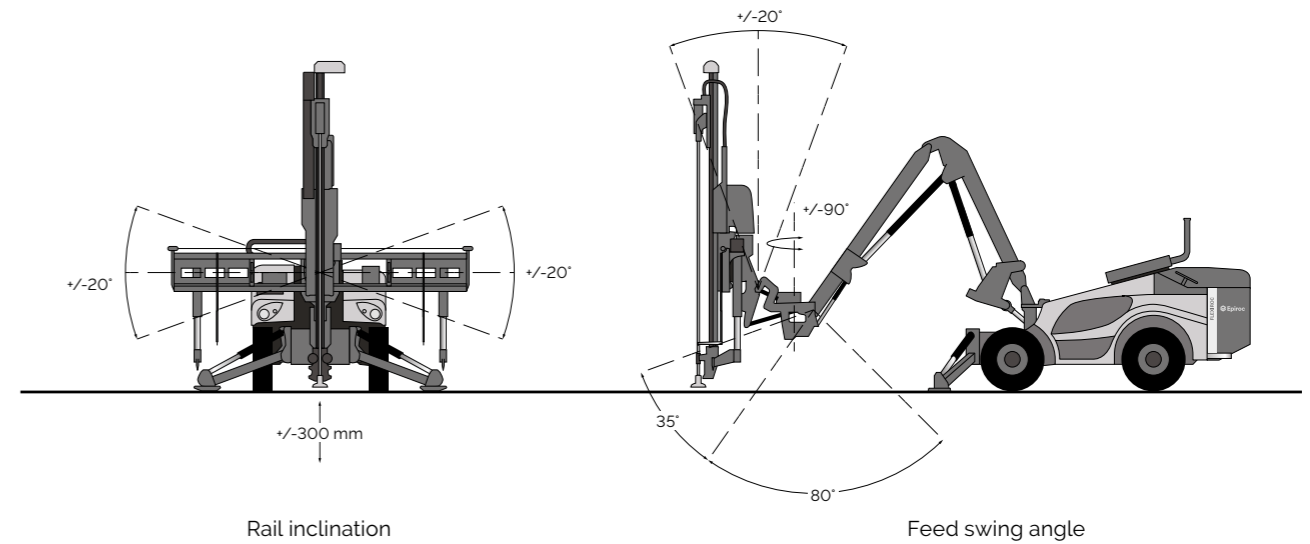

**Optional equipment**

- Drill rod extractor.
- Kit for horizontal cutting available only on 2.4 feed length.
- Automatic drilling device measuring hole depth and distance between holes.

# United in performance. Inspired by innovation.

Performance unites us, innovation inspires us, and commitment drives us to keep moving forward. Count on Epiroc to deliver the solutions you need to succeed today and the technology to lead tomorrow.  
**[epiroc.com](https://www.epiroc.com)**

